

# BENG 186B Winter 2018 Final

Thursday, March 22, 2018

*Last Name, First Name:* \_\_\_\_\_

- This final is closed book and closed notes. You may use a calculator for algebra and arithmetic.
- This final has 21 pages, including this cover sheet. Do not attach separate sheets. If you need more space, use the back of the pages.
- Circle or box your final answers and show your work on the pages provided.
- There are 10 problems. Points for each problem are given in **[brackets]**. There are 100 points total.
- You have 3 hours to complete this final.

1	/16
2	/12
3	/18
4	/6
5	/6
6	/8
7	/12
8	/8
9	/10
10	/4
<b>Total</b>	<b>/100</b>

You may find the following equations useful:

$$\omega_n = \frac{1}{\sqrt{LC}} \quad \zeta = \frac{1}{2}RC\omega_n$$

$$R = R_G (1 + G\epsilon) \quad \sigma = E\epsilon$$

$$V_o = A_d V_d + A_c V_{cm}$$

$$V_d = V_b - V_a$$

$$V_{cm} = (V_b + V_a)/2$$

$$V = \mathbf{M} \cdot \mathbf{r} = \cos\theta |\mathbf{M}| |\mathbf{r}|$$

$$\mathbf{e} = \int_0^\ell \mathbf{v} \times \mathbf{B} d\ell$$

$$\Delta f = \frac{v}{c} (\cos\theta_r + \cos\theta_s) f_s$$

$$V = E_{\text{glass}} - E_{\text{ref}} + E_{\text{Nernst}}$$

$$E_{\text{Nernst}} = \frac{RT}{nF} \ln(10) \log_{10} \left( \frac{[\text{A}^n]_{\text{out}}}{[\text{A}^n]_{\text{in}}} \right) \text{ for some ion } \text{A}^n \text{ with valence } n$$

$$V_m = \frac{RT}{F} \ln(10) \log_{10} \frac{P_{\text{Na}}[\text{Na}^+]_o + P_{\text{K}}[\text{K}^+]_o + P_{\text{Cl}}[\text{Cl}^-]_i}{P_{\text{Na}}[\text{Na}^+]_i + P_{\text{K}}[\text{K}^+]_i + P_{\text{Cl}}[\text{Cl}^-]_o}$$

$$\frac{RT}{F} \ln(10) = 62 \text{ mV at room temperature}$$

$$I = 4F [\text{O}_2] \phi \quad F = 96485 \text{ C/mol}$$

$$\log_{10} \text{PCO}_2 = -\text{pH} + \text{constant}$$

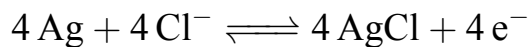
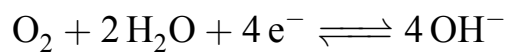

$$A(\lambda) = W L a(\lambda)$$

$$I_d = \frac{1}{1 - \exp(-d/\tau)} I_r$$

The following diagrams may come handy as well:

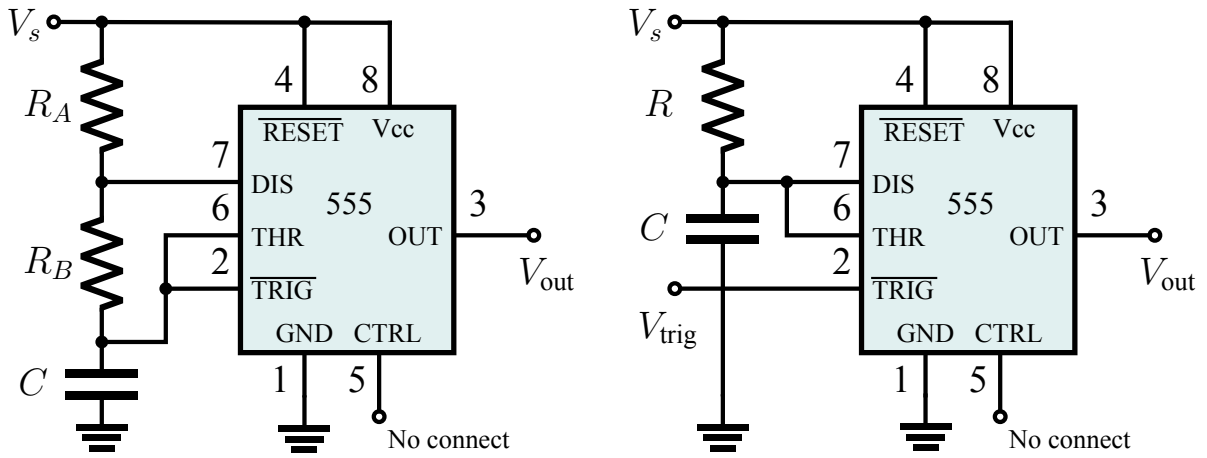

$$T_{hi} = 0.7(R_A + R_B)C$$

$$T_{lo} = 0.7R_B C$$

$$T = 1.1RC$$

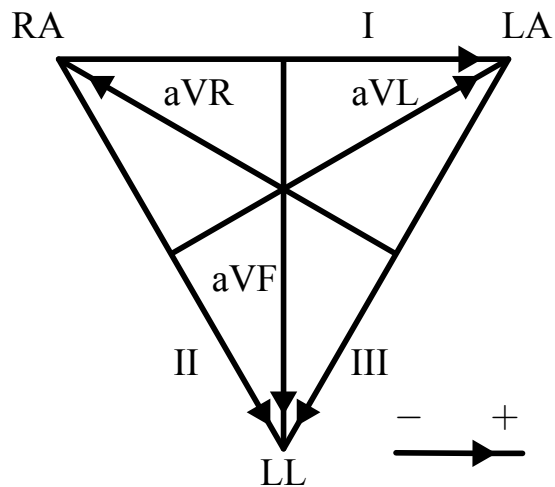

1. [16 pts] Circle the **best answer (only one answer per question)**:

(a) [1 pt] A pressure transducer with a range of 10 kPa and digital readout with an accuracy of 0.5 % requires an analog-to-digital converter with at least:

- i. 8-bit resolution
- ii. 10-bit resolution
- iii. 10-bit precision
- iv. 11-bit sensitivity
- v. none of the above

(b) [1 pt] The circuit shown below implements what function?

- i. Oscillator
- ii. Astable multivibrator
- iii. Monostable single-shot
- iv. Hysteretic comparator
- v. None of the above

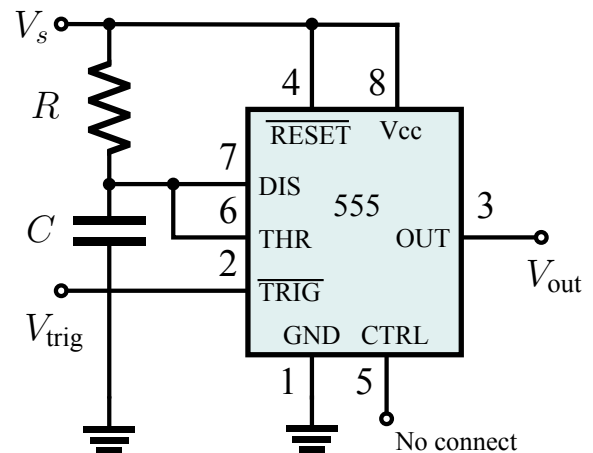

(c) [1 pt] Action potential propagate at faster velocity in axons that are myelinated, due to their:

- i. Increased membrane capacitance
- ii. Lower intracellular resistivity
- iii. Greater sodium channel conductance
- iv. Lower potassium channel conductance
- v. None of the above

(d) [1 pt] The angular coordinates of the eyeballs can be derived from electrophysiological measurement of the:

- i. ENG
- ii. EMG
- iii. ERG
- iv. EOG
- v. None of the above

- (e) [1 pt] The saturation of oxygen in the blood can be derived from measurement of:
- i.  $PO_2$  and pH and temperature
  - ii.  $PO_2$  and  $PCO_2$
  - iii.  $PCO_2$  and temperature
  - iv.  $SCO_2$
  - v. All of the above.
- (f) [1 pt] The Severinghaus electrode:
- i. Measures saturation of oxygen in the blood.
  - ii. Measures the electrocardiogram non-invasively.
  - iii. Measures acidity caused by carbon dioxide content.
  - iv. Produces hydrogen peroxide in amperometric sensing of oxygen flow.
  - v. None of the above.
- (g) [1 pt] Which one of these devices could you use to measure blood pressure?
- i. A micro-tipped manometer with a pressure transducer embedded at the tip of a catheter.
  - ii. A fluid-filled catheter with a pressure transducer embedded at its tip.
  - iii. A sphygmomanometer that uses a catheter inserted into a vessel.
  - iv. A tonometer that induces an electric field across a vessel to measure changes in the potential.
  - v. All of the above.
- (h) [1 pt] The rheobase current:
- i. Is the current injected into extracellular space by an electrically active cell.
  - ii. Is the net current flowing through the cell membrane at thermal equilibrium.
  - iii. Is the minimum steady-state current injected into the body potentially causing harm.
  - iv. Is the major cause of cardiac arrest.
  - v. None of the above.

- (i) [8 pts] Indicate for each statement below whether it is true or false:
- i. **TRUE / FALSE:** A piezoelectric crystal transduces pressure into voltage and vice versa.
  - ii. **TRUE / FALSE:** A rectifier produces a constant output voltage independent of load current.
  - iii. **TRUE / FALSE:** The current monopole generates an electric potential proportional to current and inversely proportional to distance.
  - iv. **TRUE / FALSE:** The Ag/AgCl electrode is a polarizable electrode.
  - v. **TRUE / FALSE:** The T wave in the electrocardiogram manifests atrial repolarization.
  - vi. **TRUE / FALSE:** A critically damped second-order system settles fast to input transients.
  - vii. **TRUE / FALSE:** The let-go current is the maximum current that allows the subject to withdraw.
  - viii. **TRUE / FALSE:** The point of entry of current in the body is critically important to physiological effects.

2. [12 pts] Analyze the voltage-in, voltage-out circuit shown below. You may assume the opamp is ideal, and all resistance values have zero error tolerance.

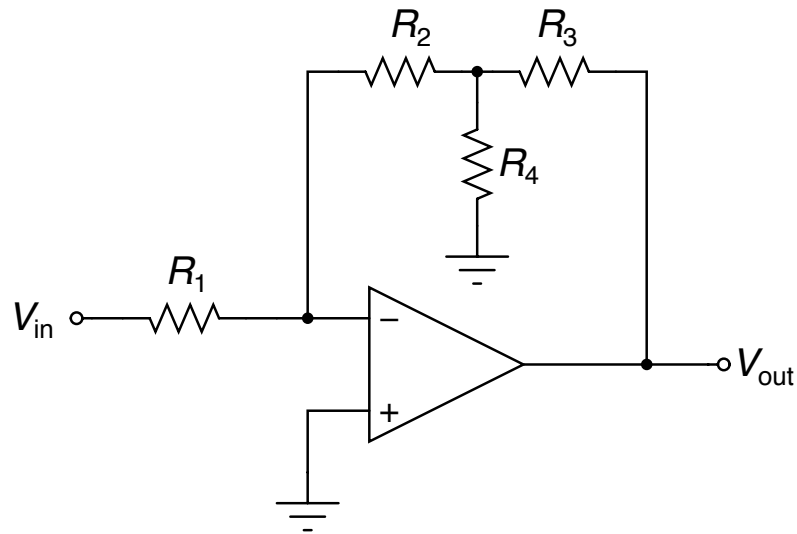

- (a) [6 pts] Find the output voltage  $V_{out}$  as a function of the input voltage  $V_{in}$ , and the voltage gain of the circuit. You may assume that the series resistances  $R_2$  and  $R_3$  in the feedback are much larger than the shunt resistance  $R_4$ .

(b) [3 pt] Find the input impedance.

(c) [3 pt] Find the output impedance.



3. [18 pts] Now analyze the following current-in, current-out filter circuit, again with zero-error tolerance passive components:

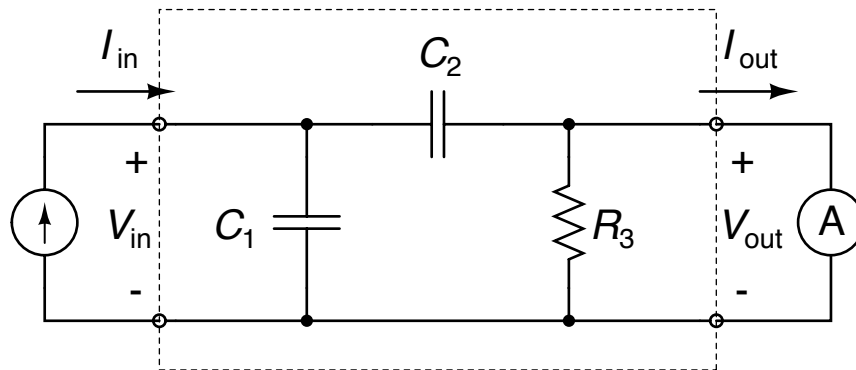

- (a) [1 pts] What is the impedance of the ideal current source driving the input of the filter?
- (b) [1 pts] What is the impedance of the ideal current meter loading the output of the filter?
- (c) [4 pt] Find the transfer function  $H(j\omega) = I_{out}(j\omega)/I_{in}(j\omega)$ . Does it depend on frequency?

(d) [3 pts] Find the input impedance  $Z_{in}(j\omega)$  of the filter.

(e) [3 pts] Find the output impedance  $Z_{out}(j\omega)$  of the filter.

- (f) [6 pt] Sketch the Bode plot of the output impedance  $Z_{out}(j\omega)$  from 0.1 Hz to 10 kHz, for  $C_1 = C_2 = 50$  nF and  $R_3 = 47$  k $\Omega$ . Be sure to indicate all units.

4. [6 pts] A Wheatstone bridge with two complementary strain gauges as shown below is used as a transducer to measure stress  $\sigma$  by an output voltage  $V_o$ . Each strain gauge has Young's modulus  $E$ , gauge factor  $G$ , and nominal resistance  $R_G$ . The other two resistances  $R_1$  and  $R_2$  in the bridge are constant and nominally equal.

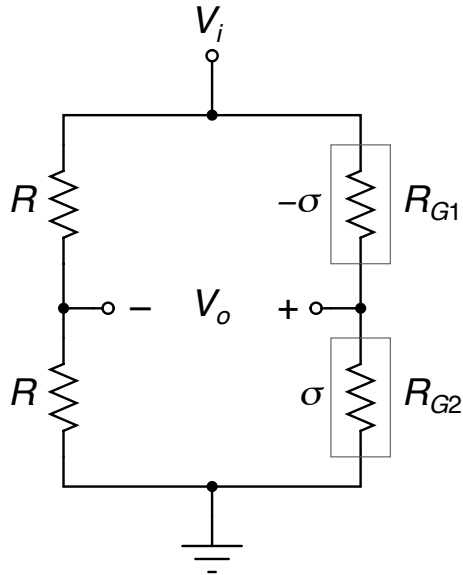

- (a) [4 pts] Find the output voltage  $V_o$  as a function of stress  $\sigma$ .

- (b) [2 pt] Find the sensitivity. Does it depend on the stress  $\sigma$ , and why?

5. **[6 pts]** You have access to three voltages  $RA$ ,  $LA$ , and  $LF$  as measured on the right arm, left arm, and left foot, respectively. Furthermore, you have access to three additional voltages as pairwise linear combinations  $(RA + LA)/2$ ,  $(LA + LF)/2$ , and  $(RA + LF)/2$  obtained from the first three voltages through equal-resistance voltage dividers. Complete the table below, choosing for each of the 6 leads of the frontal electrocardiogram which of these 6 voltages to connect to the non-inverting ( $V_A$ ) and inverting ( $V_B$ ) inputs of the instrumentation amplifier.

Lead	$V_A$	$V_B$
I		
II		
III		
aVR		
aVL		
aVF		

6. **[8 pts]** Design a voltage-in, voltage-out circuit that receives a voltage  $V_{in}$  from a pressure sensor at its input, and produces a voltage  $V_{out}$  at its output that pulses high (3 V) for 0.1 s as soon as  $V_{in}$  goes above 2 V. No new pulse should be generated until  $V_{in}$  first goes below 1 V and then goes again above 2 V. Include also short-circuit protection at the input and output, drawing no more than 10 mA from an accidental short. You may use any active devices that you learned in class, any combination of resistors and capacitors, and a single 3 V battery. You may also assume that all active devices include protection diodes to the power supplies at their input and output terminals.

7. **[12 pts]** Cardiovascular health is monitored using a variety of non-invasive bioinstruments. Here we consider two of these: a Doppler effect blood flow meter, and a pulse oximeter.

(a) [4 pts] A Doppler effect flow meter is used to measure blood velocity in a vessel with 5 mm diameter. The Doppler transducer is oriented at  $\theta_r = \theta_s = 45^\circ$  angles with respect to the vessel and transmits a 3 MHz ultrasonic signal from the source. The frequency of ultrasonic waves detected at the receiver is 200 kHz lower. Assuming that the blood velocity is uniform throughout the vessel (ignoring viscosity at the vessel walls), and accounting for ultrasonic wave propagation at 1,500 m/s in tissue and blood, estimate the volumetric flow rate of blood in the vessel.

(b) [2 pts] List two ways by which Doppler measurement can be made spatially selective to confine the measurement of blood flow to a precise region of interest.

- (c) [4 pts] A pulse oximeter is used to measure oxygen saturation in the blood. Given spectral measurements of the absorptivities  $a_o(\lambda)$  and  $a_r(\lambda)$  of oxygenated and reduced hemoglobin as a function of wavelength  $\lambda$ , which coincide at the isosbestic wavelength  $\lambda_i$  (*i.e.*,  $a_i = a_o(\lambda_i) = a_r(\lambda_i)$ ), find an expression for  $SO_2$  as a function of measurements of absorbance in the vessel at two wavelengths,  $A(\lambda)$  and  $A(\lambda_i)$  where  $\lambda_i \neq \lambda$ . How would you choose  $\lambda$  to maximize sensitivity?
- (d) [2 pts] Explain briefly how to obtain an estimate of absorbance in the vessel from non-invasive measurement of transmitted or reflected intensity on the skin surface, by separating AC pulsing and DC steady-state components in the received optical signal.



8. **[8 pts]** Consider the pH meter below to measure acidity level in a sample of blood. One Ag/AgCl electrode is immersed in the blood sample at room temperature, and a second Ag/AgCl electrode inside a glass bulb containing a solution of 10 mmol/L KCl in water. The glass membrane is permeable to  $H^+$  only. For each Ag/AgCl electrode, the half cell potential is  $E_{hc} = 0.223\text{ V}$  and the impedance parameters are  $R_d = 100\text{ k}\Omega$ ,  $C_d = 100\text{ pF}$ , and  $R_s = 100\ \Omega$ .

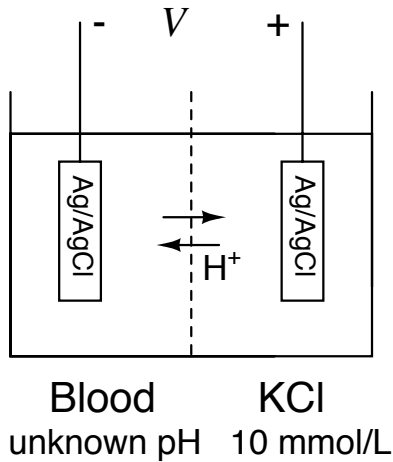

Each Ag/AgCl electrode:

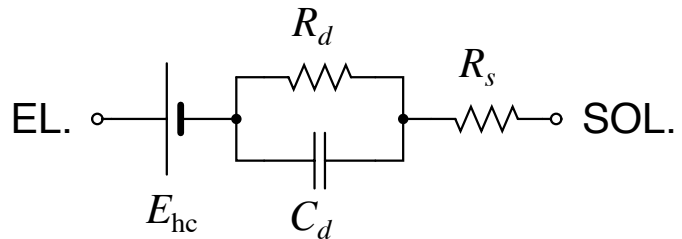

- (a) [2 pts] Find the pH inside the glass bulb.
- (b) [2 pts] The voltage  $V$  on the glass electrode relative to the reference electrode measures 62 mV. Find the pH of the blood sample.

(c) [3 pts] Assuming the electrical resistance across the glass membrane is  $R_{mem} = 200 \text{ k}\Omega$ , and neglecting the resistance in ionic solution, find the equivalent resistance between the two electrodes at high frequencies.

(d) [1 pt] Explain briefly how to extend the experimental setup to measure  $\text{PCO}_2$ .

9. [10 pts] Consider the combined instrumentation amplifier (IA) and driven right leg (DRL) system below with resistances  $R_1 = R_4 = 1\text{ M}\Omega$ ,  $R_2 = R_3 = 10\text{ k}\Omega$ , and  $R_f = 1\text{ M}\Omega$ , and with electrode resistances  $R_{RA} = 105\text{ k}\Omega$ ,  $R_{LL} = 95\text{ k}\Omega$ , and  $R_{RL} = 100\text{ k}\Omega$ . All opamp input impedances are  $R_{in} = 1\text{ G}\Omega$ .

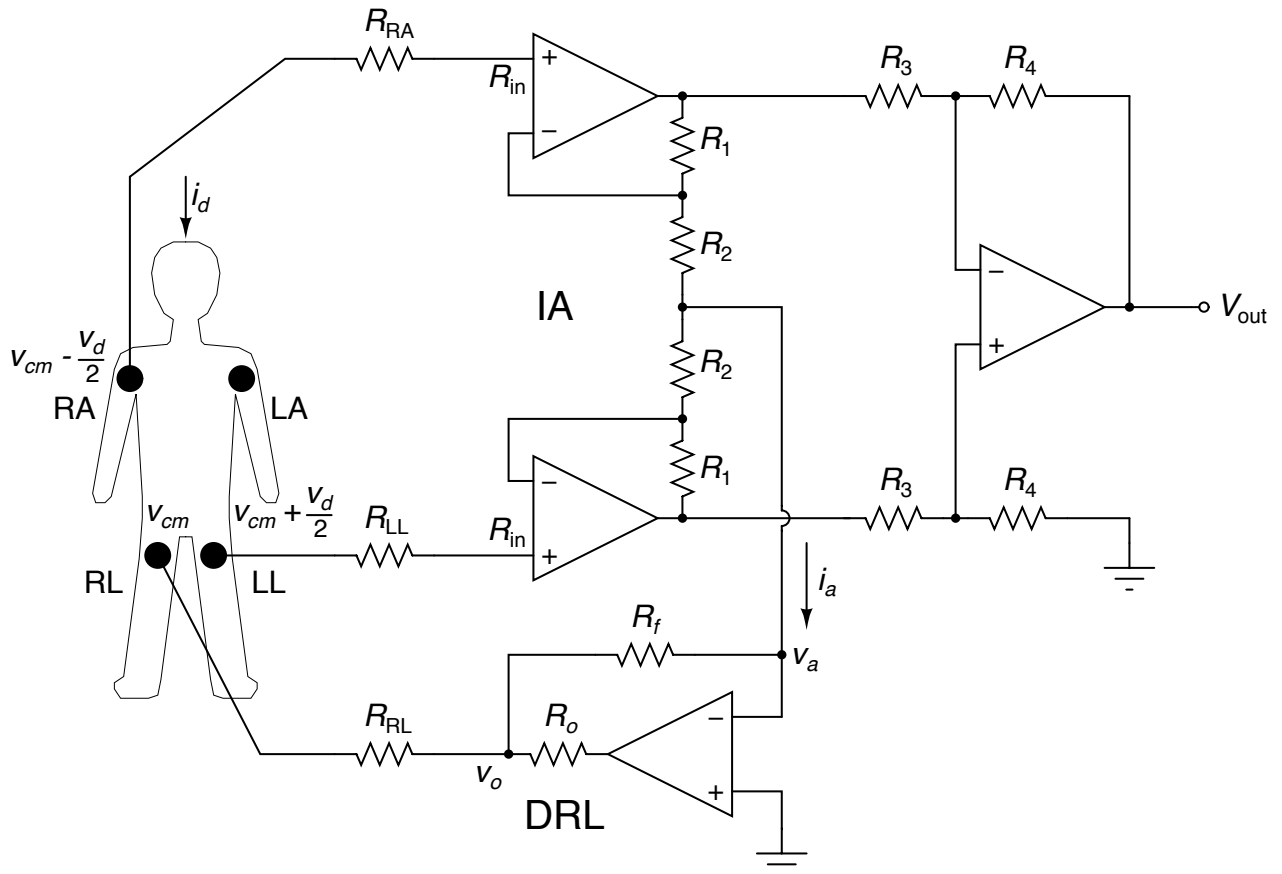

- (a) [3 pts] Find the voltage  $v_a$  at the DRL input node, and the current  $i_a$  entering the DRL input node in terms of the body common-mode voltage  $v_{cm}$ .

(b) [3 pts] Find the corresponding effective right-leg resistance  $R_{RL\text{ eff}} = v_{cm}/i_d$ .

(c) [3 pts] Find the differential gain  $A_d$ , and effective common-mode rejection ratio  $\text{CMRR}_{\text{eff}}$ .

(d) [1 pts] Find the value for  $R_o$  to limit the short-circuit current on the DRL electrode to no more than  $10\ \mu\text{A}$  for a  $\pm 1\ \text{V}$  double rail voltage supply.

10. [4 pts] Guest lectures

(a) *Dry-electrode EEG systems*

i. [1 pt] Which factors contribute to the signal quality of dry-electrode electroencephalography recording?

ii. [1 pt] Which signal is typically observed from an electrode on the occipital lobe when the subject closes the eyes?

(b) *Global health and wearables*

i. [1 pt] To what extent would raising the GDP in the third world help to increase life expectancy?

ii. [1 pt] For a wearable device to be capable of measuring the 6-lead frontal electrocardiogram, which body parts need to come in direct contact with the device?