

BENG 186B Winter 2020

Quiz 2

Friday, February 14, 2020

Last Name, First Name: SOLUTIONS

- This quiz is closed book and closed notes. You may use a calculator for algebra and arithmetic.
- Do not attach separate sheets. If you need more space, use the back of the pages.
- Circle or box your final answers and show your work on the pages provided.
- There are 4 problems. Points for each problem are given in [**brackets**]. There are 100 points total.
- The quiz takes 50 minutes to complete.

1. [25 pts] Consider the current-in, voltage-out active filter circuit below. Assume the operational amplifier is ideal and unsaturated.

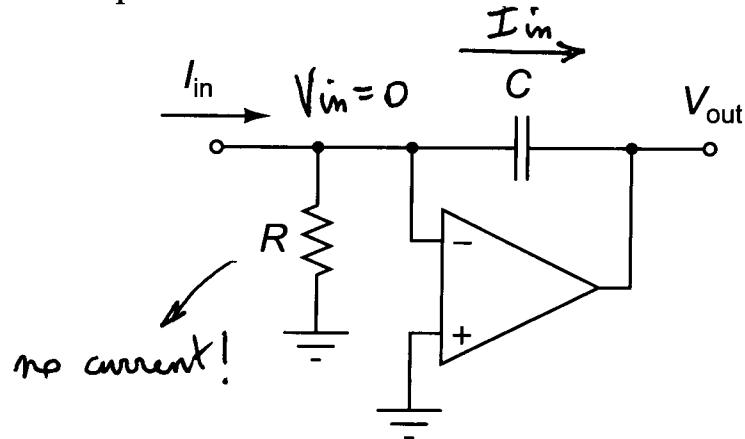

- (a) [10 pts] Derive the transfer function $H(j\omega) = V_{out}(j\omega) / I_{in}(j\omega)$. What type of filter is this?

Virtual ground : $V_{in} = 0$

KCL @ V_{in} : $I_{in} = j\omega C \cdot (-V_{out})$

$$\Rightarrow H(j\omega) = \frac{V_{out}}{I_{in}} = -\frac{1}{j\omega C}$$

INTEGRATOR

(or: lowpass filter with zero cut-off frequency)

- (b) [10 pts] What is the input impedance at the I_{in} node? Does your answer depend on R , and why?

$$V_{in} = 0 \text{ regardless of } I_{in}$$
$$\Rightarrow Z_{in} = 0$$

independent of R , since it is shorted by the virtual ground.

- (c) [5 pts] What is the output impedance at the V_{out} node?

$$V_{out} \text{ is independent of } I_{out}$$
$$\Rightarrow Z_{out} = 0$$

2. [30 pts] Consider the bioinstrumentation circuit below with ideal 555 and opamp components. The values for the passive components are $R_1 = 1 \text{ k}\Omega$, $R_2 = 999 \text{ k}\Omega$, $R_3 = 10 \text{ k}\Omega$, $R_4 = 90 \text{ k}\Omega$, $R = 450 \text{ k}\Omega$, and $C = 1 \mu\text{F}$. You may also find these equations useful for the 555 timer ($\ln(3) \approx 1.1$ and $\ln(2) \approx 0.7$):

$$T = \ln(3) \times RC \quad T_{lo} = \ln(2) \times R_2 C \quad T_{hi} = \ln(2) \times (R_1 + R_2) C$$

On the diagrams on the next page sketch the waveforms for the voltages $V_A(t)$, $V_B(t)$ and $V_{out}(t)$ for the given waveform for $V_{in}(t)$ (note the different voltage scales). Show your work below.

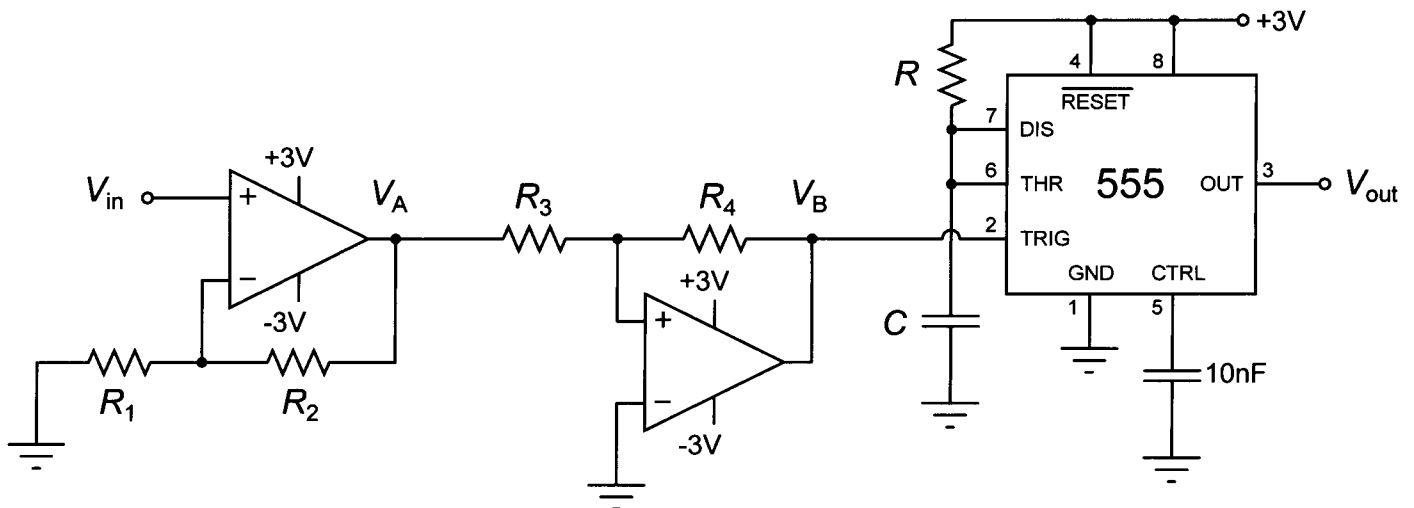

NON-INVERTING
AMPLIFIER

NON-INVERTING
HYSTERETIC COMPARATOR

MONOSTABLE
SINGLE-SHOT

$$\text{Gain} = 1 + \frac{R_2}{R_1}$$

$$= 1 + 999 = 1000$$

Thresholds:

$$V_{th}^{\pm} = \frac{R_3}{R_4} (\pm 3V)$$

$$= \pm \frac{10}{90} 3V$$

$$= \pm 0.33 V$$

$$T = \ln(3) RC$$

$$= 1.1 \cdot 450 \text{ k}\Omega \cdot 1 \mu\text{F}$$

$$= 495 \text{ ms}$$

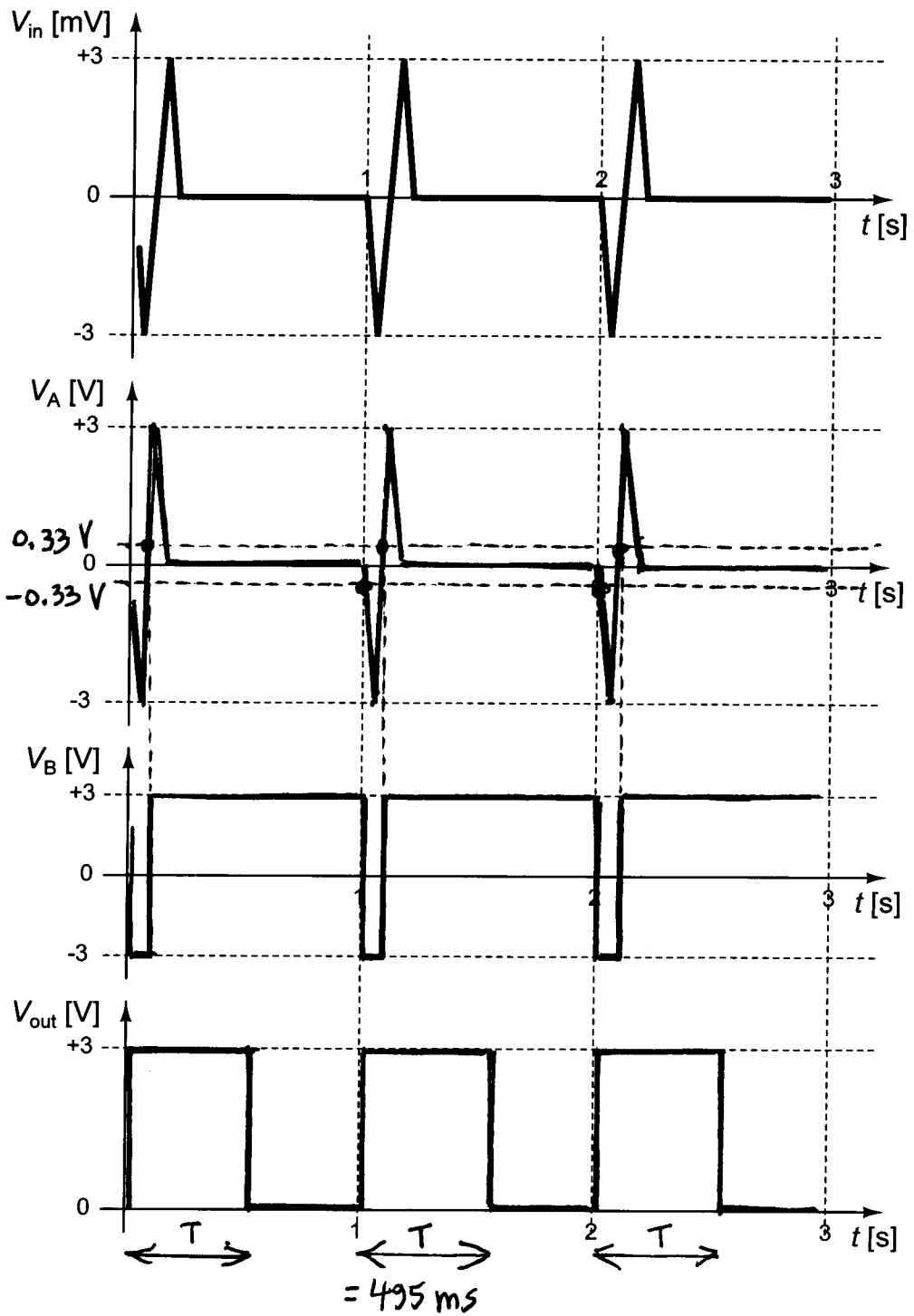

3. [20 pts] Circle the best answer (only one answer per question):

(a) [4 pts] Find the simplest logical expression for the output of the circuit shown at right:

- i. $OR(A, B)$
- ii. $OR(A, NOT(B))$
- iii. $AND(A, B)$
- iv. 0
- v. 1

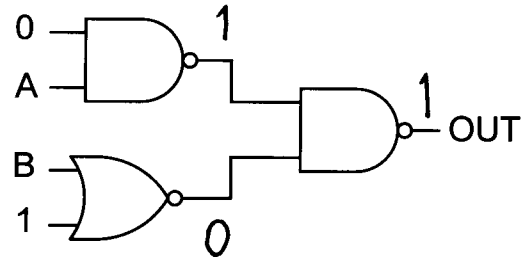

(b) [4 pts] The ideal opamp:

- i. draws no current at its inputs.
- ii. has infinite gain for zero differential input.
- iii. saturates for nonzero differential input.
- iv. none of the above.
- v. all of the above.

(c) [4 pts] The QRS complex in the electrocardiogram denotes:

- i. atrial defibrillation.
- ii. atrial depolarization.
- iii. ventricular repolarization.
- iv. none of the above.
- v. all of the above.

(d) [1 pt ea.] Indicate for each statement below whether it is true or false:

- i. **TRUE** / **FALSE**: Myelinated axons have larger capacitance due to the presence of a myelin sheath.
- ii. **TRUE** / **FALSE**: ENG measures skeletomuscular activity in the peripheral nervous system.
- iii. **TRUE** / **FALSE**: ERG measures transient response of the retina to a flash of light.
- iv. **TRUE** / **FALSE**: EEG measures brain wave activity originating mostly from cortex.
- v. **TRUE** / **FALSE**: The current dipole is used as a simple model to approximate biopotentials due to volume conduction of currents from various organs in the body.
- vi. **TRUE** / **FALSE**: Electrical resistance through dry skin is much larger than across the volume of the body.
- vii. **TRUE** / **FALSE**: The magnitude of electrode-electrolyte impedance increases with frequency.
- viii. **TRUE** / **FALSE**: Polarizable electrodes freely pass both positive and negative currents.

4. [25 pts] Consider an electrochemical cell at room temperature, with two compartments of ionic solutions each containing KCl and NaCl with concentrations given in the table below. The two compartments are separated by a membrane that is equally permeable to Na^+ and Cl^- , but impermeable to all other ion types including K^+ . Two identical Ag/AgCl electrodes are inserted, one in each compartment. The GHK equation at room temperature is:

$$V_m = 60 \text{ mV} \times \log_{10} \left(\frac{P_{\text{Na}}[\text{Na}^+]_o + P_{\text{K}}[\text{K}^+]_o + P_{\text{Cl}}[\text{Cl}^-]_i}{P_{\text{Na}}[\text{Na}^+]_i + P_{\text{K}}[\text{K}^+]_i + P_{\text{Cl}}[\text{Cl}^-]_o} \right)$$

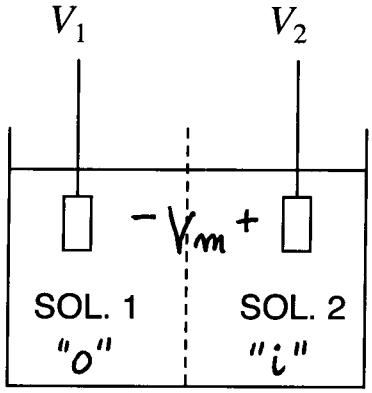
V_1

\uparrow
 P

\uparrow
 0

\uparrow
 P

$"o"$

$"i"$

	SOL. 1	SOL. 2
KCl	20 mmol/L	650 mmol/L
NaCl	40 mmol/L	10 mmol/L
Na^+	40 mmol/L	10 mmol/L
Cl^-	60 mmol/L	660 mmol/L

- (a) [15 pts] Find the voltage $V_2 - V_1$ between the electrodes measured by an ideal voltmeter.

$$\begin{aligned}
 V_2 - V_1 &= \cancel{E_{\text{Ag/AgCl}}} - \cancel{E_{\text{Ag/AgCl}}} + V_m \\
 &= 60 \text{ mV} \log_{10} \frac{40 + 0 + 660}{60 + 0 + 10} \\
 &= 60 \text{ mV} \log_{10} \frac{700}{70} = 60 \text{ mV} \\
 &\quad \underbrace{\qquad\qquad\qquad}_{=10} \\
 &\quad \underbrace{\qquad\qquad\qquad}_{=1}
 \end{aligned}$$

- (b) [10 pts] Now you remove the membrane separating the two solutions, and wait for the solutions to fully mix. What voltage $V_2 - V_1$ do you then measure with the ideal voltmeter between the two electrodes? And what current do you measure with an ideal ammeter between the two electrodes?

$$V_2 - V_1 = \cancel{E_{\text{O}_{2g}/\text{H}_2\text{O}_2}} - \cancel{E_{\text{O}_{2g}/\text{H}_2\text{O}_2}} = 0 \quad (\text{no membrane})$$

$$I = \frac{\cancel{E_{\text{O}_{2g}/\text{H}_2\text{O}_2}} - \cancel{E_{\text{O}_{2g}/\text{H}_2\text{O}_2}}}{Z_{el} + Z_{sol} + Z_{el}} = \frac{0}{\text{whatever}} = 0$$

