

# BENG 186B Winter 2022

## Quiz 2

Friday, February 11, 2022

*Name (Last, First):* \_\_\_\_\_

- This quiz is on-line, open-book, and open-notes, but web search is prohibited. You may follow electronic links from Canvas or the class web pages, but not any further. **No collaboration or communication in any form is allowed**, except for questions to the instructor and TAs.
- The quiz is due February 11, 2022 at 11:59pm, over Canvas Gradescope. It should approximately take 2 hours to complete, but there is no time limit other than the submission deadline. Do not discuss any class-related topics among yourselves before or after you have completed your quiz, and until the submission deadline has passed.
- There are 4 problems. Points for each problem are given in **[brackets]**. There are 100 points total.

1. [25 pts] Consider the *voltage-in, voltage-out* active filter circuit below. Assume the operational amplifier is ideal and unsaturated.

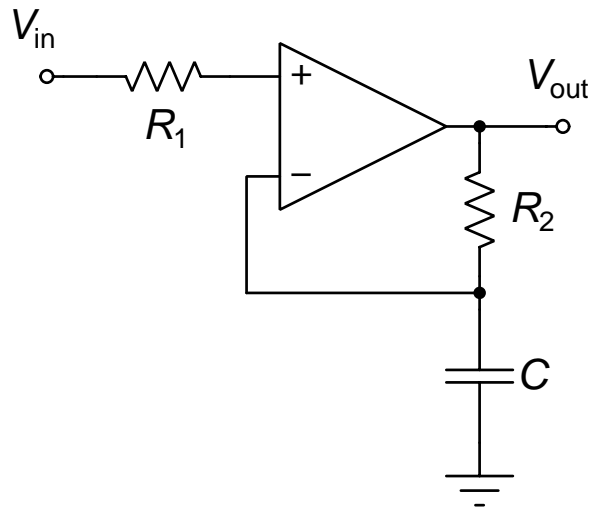

- (a) [15 pts] Derive the transfer function  $H(j\omega) \equiv V_{out}(j\omega) / V_{in}(j\omega)$ . Find any poles and zeros, and describe what this filter does.

(b) [5 pts] What is the input impedance at the  $V_{in}$  node? Does your answer depend on  $R_1$ , and why?

(c) [5 pts] What is the output impedance at the  $V_{out}$  node?

2. [30 pts] Consider the bioinstrumentation circuit below with ideal 555 and opamp components. The values for the passive components are  $R_1 = 10\text{ k}\Omega$ ,  $R_2 = 19.99\text{ M}\Omega$ ,  $R_3 = 20\text{ k}\Omega$ ,  $R_4 = 100\text{ k}\Omega$ ,  $R = 909\text{ k}\Omega$ , and  $C = 1\text{ }\mu\text{F}$ . You may also find these equations useful for the 555 timer ( $\ln(3) \approx 1.1$  and  $\ln(2) \approx 0.7$ ):

$$T = \ln(3) \times RC \quad T_{lo} = \ln(2) \times R_2C \quad T_{hi} = \ln(2) \times (R_1 + R_2)C$$

On the diagrams on the next page sketch the waveforms for the voltages  $V_A(t)$ ,  $V_B(t)$ ,  $V_C(t)$ , and  $V_{out}(t)$  for the given waveform for  $V_{in}(t)$  (note the different voltage scales). Show your work below.

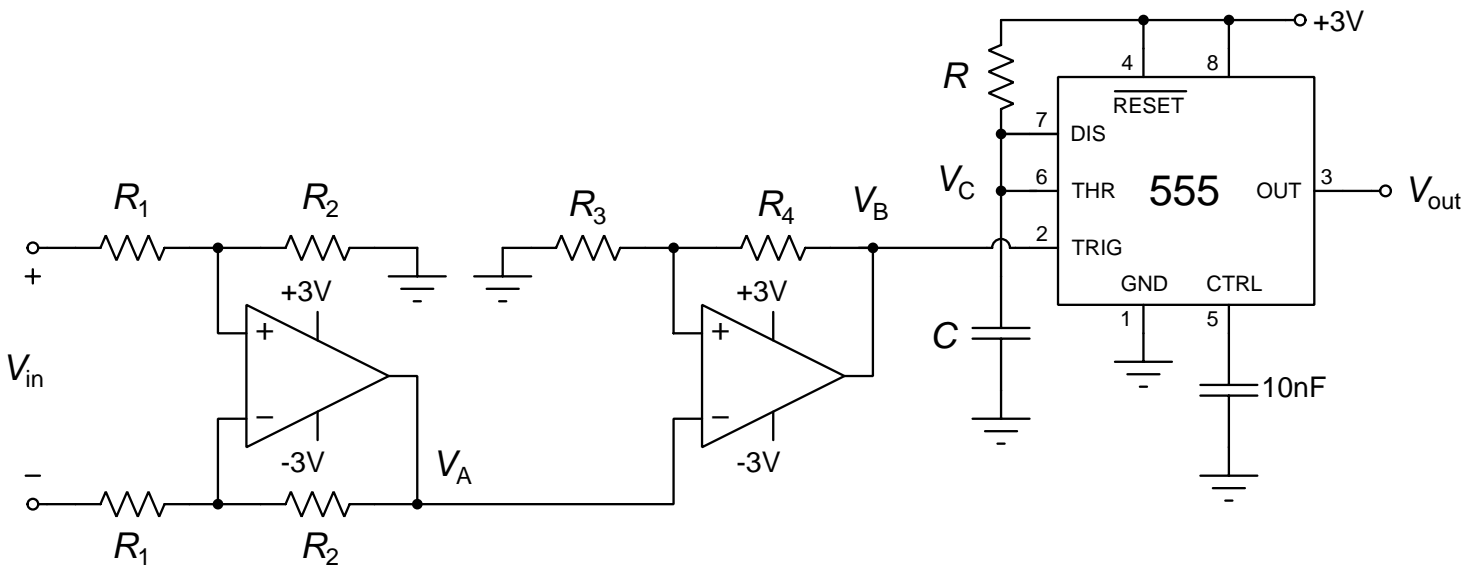

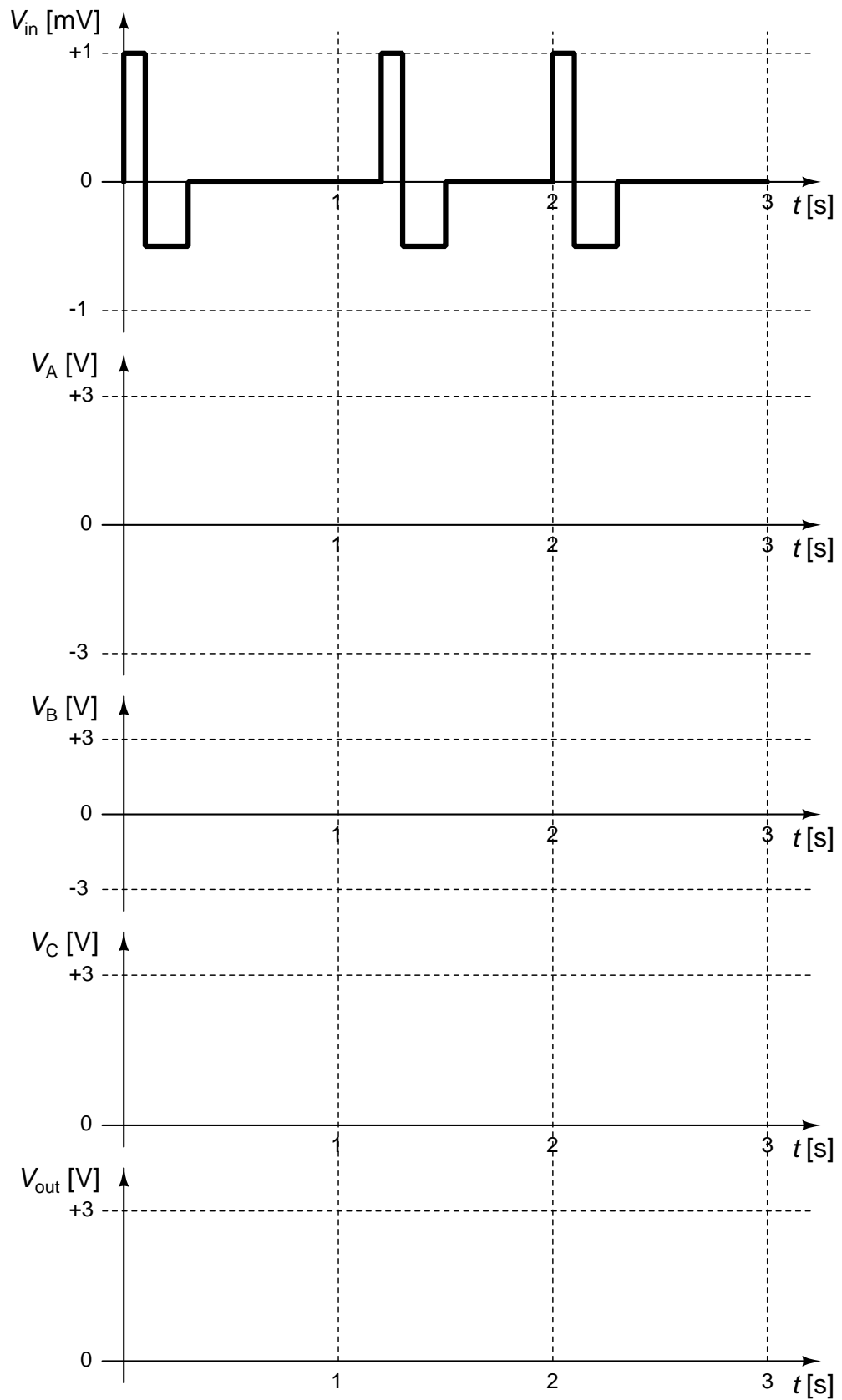

3. [20 pts] Circle the **best answer (only one answer per question)**:

(a) [4 pts] Find the simplest logical expression for the output of the circuit shown at right:

- i. A
- ii. B
- iii.  $\text{NOR}(A, B)$
- iv.  $\text{OR}(\text{NOT}(A), B)$
- v.  $\text{AND}(A, \text{NOT}(B))$

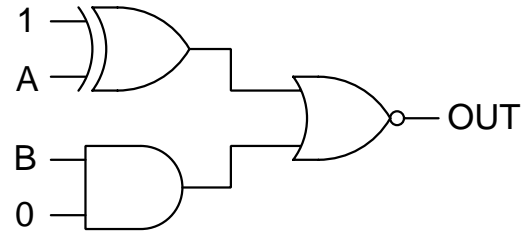

(b) [4 pts] The ideal comparator:

- i. draws zero current at its inputs.
- ii. outputs either of the supply voltages.
- iii. goes low when the differential input is negative.
- iv. none of the above.
- v. all of the above.

(c) [4 pts] The T wave in the electrocardiogram denotes:

- i. atrial defibrillation.
- ii. atrial depolarization.
- iii. ventricular repolarization.
- iv. none of the above.
- v. all of the above.

(d) [1 pt ea.] Indicate for each statement below whether it is true or false:

- i. **TRUE / FALSE:** The potential originating from a current dipole is zero along the direction of the dipole.
- ii. **TRUE / FALSE:** During its refractory period the neuron is more susceptible to excitatory input.
- iii. **TRUE / FALSE:** Nodes of Ranvier regenerate the action potential traveling along a myelinated axon.
- iv. **TRUE / FALSE:** EGG measures electrical activity in the digestive tract.
- v. **TRUE / FALSE:** EOG is a biopotential arising from a static charge dipole in the eyeball.
- vi. **TRUE / FALSE:** ECoG measures cortical wave activity originating deep in the brain.
- vii. **TRUE / FALSE:** Gel-based electrodes have higher impedance than dry-contact electrodes.
- viii. **TRUE / FALSE:** Half-cell potentials can be positive or negative depending on the electrode metal type.

4. [25 pts] Consider an electrochemical cell at room temperature, with two compartments of ionic solutions each containing KCl and NaCl with concentrations given in the table below. The two compartments are separated by a membrane that may be permeable to  $\text{Na}^+$  and  $\text{Cl}^-$ , but is impermeable to all other ion types including  $\text{K}^+$ . Two identical Ag/AgCl electrodes are inserted, one in each compartment. The GHK equation at room temperature is:

$$V_m = 60 \text{ mV} \times \log_{10} \left( \frac{P_{\text{Na}}[\text{Na}^+]_o + P_{\text{K}}[\text{K}^+]_o + P_{\text{Cl}}[\text{Cl}^-]_i}{P_{\text{Na}}[\text{Na}^+]_i + P_{\text{K}}[\text{K}^+]_i + P_{\text{Cl}}[\text{Cl}^-]_o} \right)$$

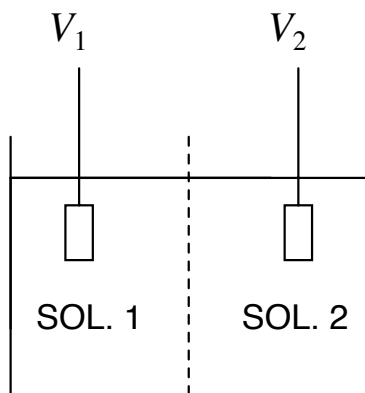

	SOL. 1	SOL. 2
KCl	99 mmol/L	0 mmol/L
NaCl	1 mmol/L	10 mmol/L

- (a) [15 pts] Find the voltage  $V_2 - V_1$  between the electrodes measured by an ideal voltmeter when the membrane is (i) permeable to  $\text{Na}^+$  only, (ii) permeable to  $\text{Cl}^-$  only, and (iii) equally permeable to both  $\text{Na}^+$  and  $\text{Cl}^-$ .

- (b) [10 pts] Now a positive  $1 \mu\text{A}$  current is injected into the first solution (SOL. 1) through the leftmost ( $V_1$ ) electrode, and the same current exits the second solution (SOL. 2) through the rightmost ( $V_2$ ) electrode. Describe what happens to the two electrodes and to the two solutions. You may assume the membrane is permeable to  $\text{Cl}^-$ .