

BENG 186B Winter 2023

Quiz 2

Friday, February 17, 2023

Last Name, First Name: _____

- This quiz is on-line, open-book, and open-notes. You may use a calculator or an equivalent program, but web search is prohibited. You may follow electronic links from Canvas or the class web pages, but not any further. **No collaboration or communication in any form is allowed**, except for questions to the instructor and TAs.
- The quiz is due February 17, 2023 at 11:59pm, over Canvas (Gradescope). It should approximately take 2 hours to complete, but there is no time limit other than the submission deadline. Do not discuss any class-related topics among yourselves before or after you have completed your quiz, and until the submission deadline has passed.
- There are 4 problems. Points for each problem are given in **[brackets]**. There are 100 points total, but also a bonus +10 points challenge.

1. [30 pts] Consider the voltage-in, voltage-out active filter circuit below:

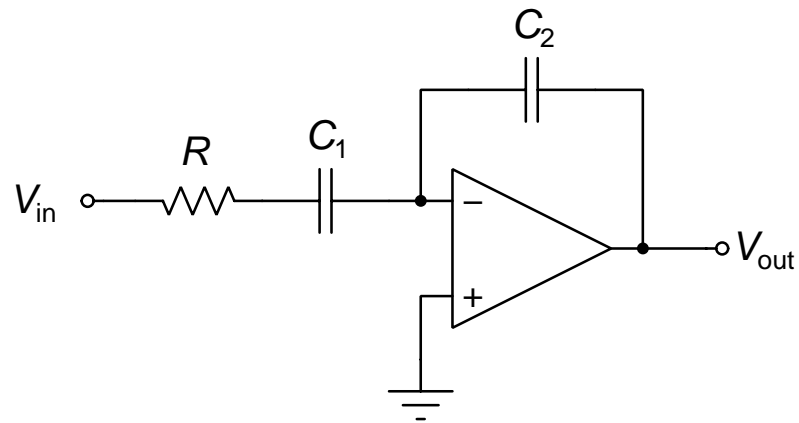

- (a) [15 pts] Assume the operational amplifier is ideal and unsaturated. Derive the transfer function $H(j\omega) = V_{out}(j\omega) / V_{in}(j\omega)$. What type of filter is this? What is the cutoff frequency?

(b) [5 pts] What is the input impedance at the V_{in} node?

- (c) [10 pts] What is the problem with this circuit at DC (zero frequency), and how would you fix it without affecting the filter characteristic at non-zero frequencies?

2. [35 pts] Consider the signal generator circuit shown below. All active components are ideal. The 555 timer IC and the opamp operate from a +3V single supply. The values for the passive components are $R = 144 \text{ k}\Omega$, $C = 10 \text{ nF}$, $R_i = 33 \text{ k}\Omega$, and $C_i = 20 \text{ nF}$. You may also find the following equations useful for the 555 timer ($\ln(3) \approx 1.1$ and $\ln(2) \approx 0.7$):

$$T = \ln(3) \times RC \quad T_{lo} = \ln(2) \times R_2C \quad T_{hi} = \ln(2) \times (R_1 + R_2)C$$

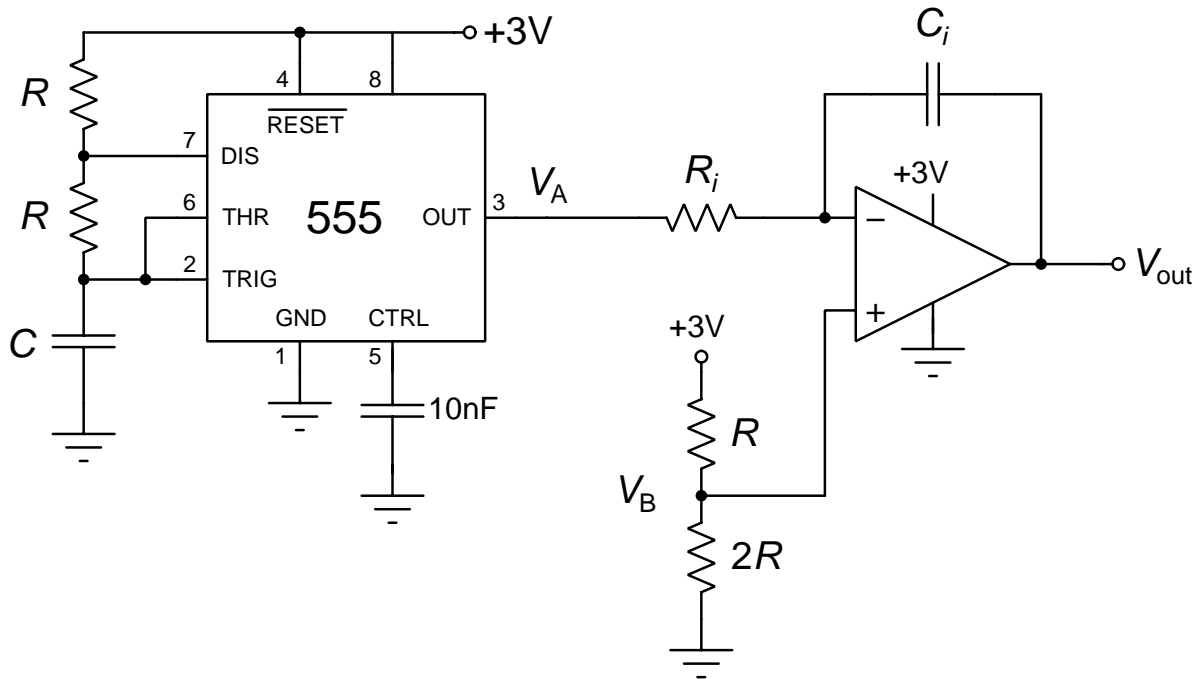

- (a) [20 pts] Sketch the waveforms for the voltages V_A , V_B and V_{out} on the diagrams on the next page. You may assume that at time $t = 0$ the voltage on the capacitor C is 1 V.

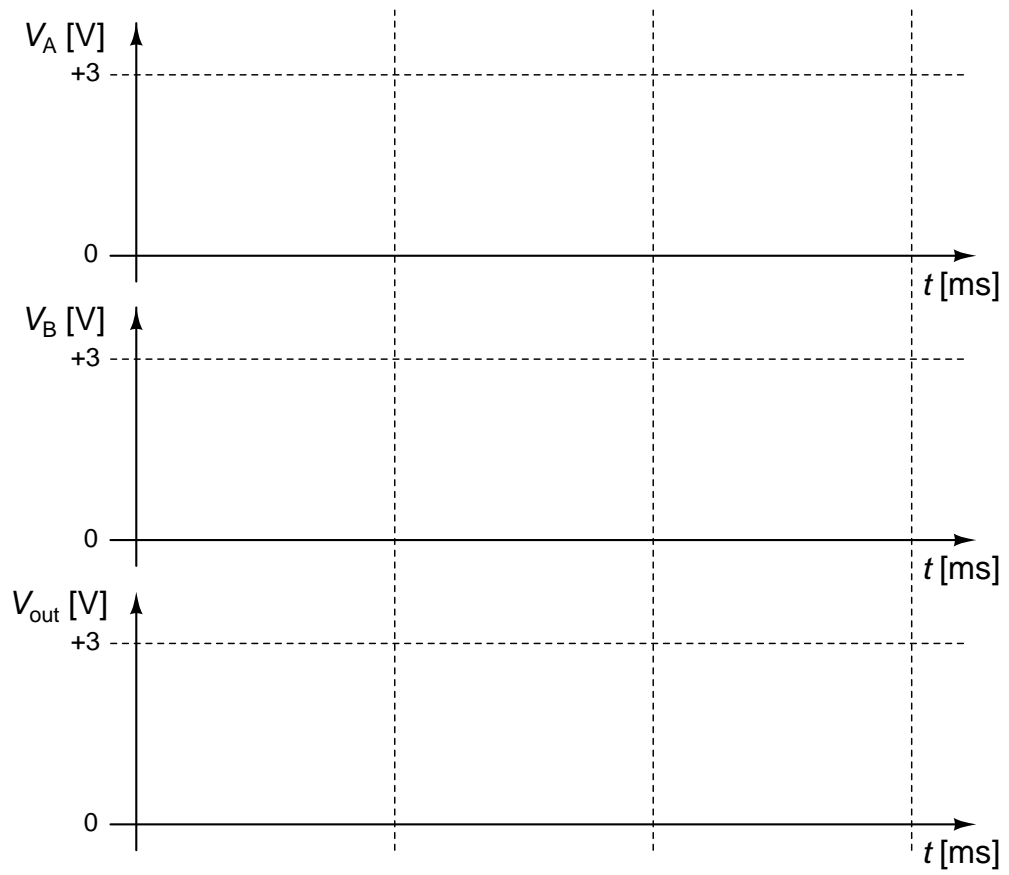

(b) [15 pts] Does the output voltage V_{out} change if the upper supply of the opamp is replaced with +2V? Explain.

3. [20 pts] Circle the **best answer (only one answer per question)**:

(a) [4 pts] The output V_{out} of the circuit shown at right (with an ideal opamp) goes low when the input V_{in} goes:

- i. below 0
- ii. above 0
- iii. below -1.5V
- iv. above +1.5V
- v. above +3V

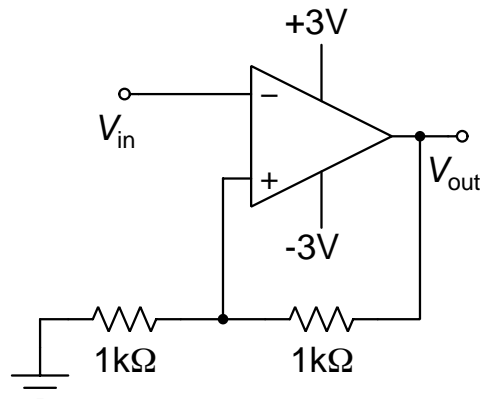

(b) [4 pts] Find the simplest logic expression for the output shown at right:

- i. 0
- ii. 1
- iii. A
- iv. \bar{B}
- v. $A \cdot \bar{B}$

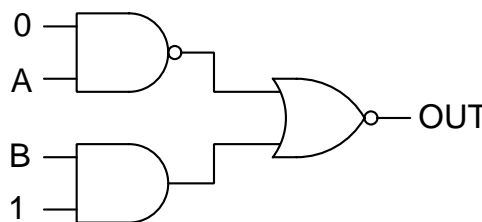

(c) [4 pts] The electrode circuit model on the right accounts for:

- i. half-cell potential
- ii. ohmic overpotential
- iii. double-layer resistance and capacitance
- iv. the electrode-electrolyte interface
- v. all of the above

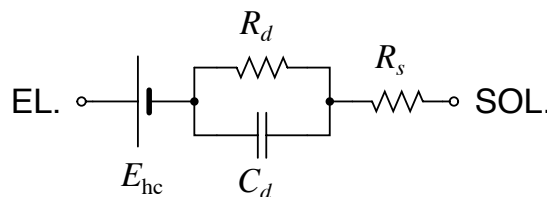

(d) [1 pt ea.] Indicate for each statement below whether it is true or false:

- i. **TRUE / FALSE:** Biopotentials arise from volume conduction of currents from electrically active cells in the body.
- ii. **TRUE / FALSE:** Current dipoles provide accurate models of local field potentials accounting for global charge balancing.
- iii. **TRUE / FALSE:** Extracellular action potentials are like the intracellular action potential, just smaller.
- iv. **TRUE / FALSE:** ERG is clinically used to diagnose retinal disorders.
- v. **TRUE / FALSE:** EGG originates in the digestive tract.
- vi. **TRUE / FALSE:** The T wave of ECG indicates atrial repolarization.
- vii. **TRUE / FALSE:** A battery can be realized by immersing two metals in electrolyte.
- viii. **TRUE / FALSE:** The Ag/AgCl electrode as a non-polarizable electrode is able to deliver an unlimited amount of charge.

4. [15 pts] A signal electrode is inserted into an electrically active cell, and a second identical reference electrode is inserted into extracellular tissue far away from the cell. The ion concentrations inside and outside the cell are given in the table below. The cell has a diameter $D = 20 \mu\text{m}$, and membrane capacitance $C_m = 1 \mu\text{F}/\text{cm}^2$. At rest (equilibrium) the cell membrane is equally permeable to all three ion types, whereas during the action potential the cell membrane is permeable to Na^+ only, and during the refractory period the cell membrane is permeable to K^+ only. The GHK equation is:

$$V_m = \frac{RT}{F} \ln(10) \log_{10} \left(\frac{P_{\text{Na}}[\text{Na}^+]_o + P_{\text{K}}[\text{K}^+]_o + P_{\text{Cl}}[\text{Cl}^-]_i}{P_{\text{Na}}[\text{Na}^+]_i + P_{\text{K}}[\text{K}^+]_i + P_{\text{Cl}}[\text{Cl}^-]_o} \right)$$

and at room temperature $RT/F \ln(10) \approx 60 \text{ mV}$.

	Inside	Outside
Na^+	10nM	100nM
K^+	100nM	10nM
Cl^-	110nM	110nM

- (a) [5 pts] Find the voltage measured by the signal electrode relative to the reference electrode when the cell is at rest.

(b) [5 pts] Find the voltage measured by the signal electrode relative to the reference electrode when the cell is at the peak of its action potential.

(c) [5 pts] Find the voltage measured by the signal electrode relative to the reference electrode when the cell is at the valley of its refractory period.

- (d) **Bonus** [extra +10 pts]: Estimate the number of sodium ions that enter the cell during its action potential, as the cell transitions from rest to the peak of the action potential. How does this affect the reversal potential for sodium, and how do these sodium ions exit the cell afterwards?