

BENG 186B Winter 2022

Quiz 3

Friday, March 4, 2022

Last Name, First Name: _____

- This quiz is on-line, open-book, and open-notes. You may use a calculator or an equivalent program, but web search is prohibited. You may follow electronic links from Canvas or the class web pages, but not any further. **No collaboration or communication in any form is allowed**, except for questions to the instructor and TAs.
- The quiz is due March 4, 2022 at 11:59pm, over Canvas. It should approximately take 2 hours to complete, but there is no time limit other than the submission deadline. Do not discuss any quiz-related material among yourselves before or after you have completed your quiz, and until the submission deadline has passed.
- There are 4 problems. Points for each problem are given in **[brackets]**. There are 100 points total.

1. [20 pts] Consider Einthoven's triangle of the frontal electrocardiogram (ECG) for the three electrodes RA, LA and LL shown below. The triangle is equilateral and the augmented lead vectors (aVR, aVL, and aVF) bisect the bipolar lead vectors (I, II, and III).

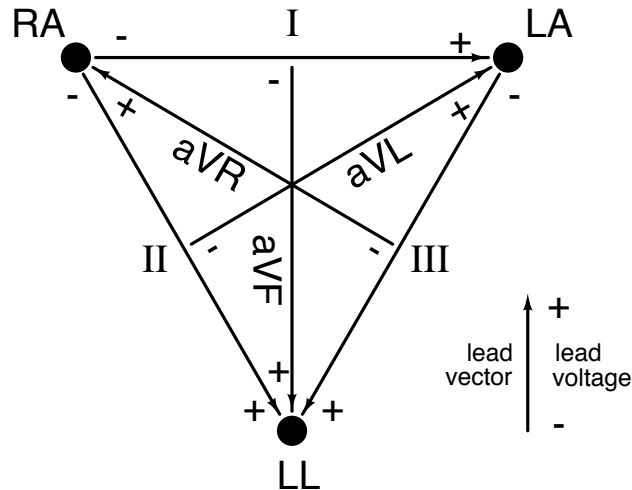

- (a) [6 pts] You are given an instrument that directly measures voltage RA on the right arm, voltage LA on the left arm, and voltage LL on the left leg, relative to the system ground on the right leg. Reconstruct the six leads of the frontal ECG from the RA, LA, and LL outputs:

$$I = \quad \quad \quad aVR =$$

$$II = \quad \quad \quad aVL =$$

$$III = \quad \quad \quad aVF =$$

- (b) [4 pts] What is the minimum number of electrodes needed to reconstruct the full 12-lead electrocardiogram? Explain.

- (c) [10 pts] You find that RA measures -2 mV, LA measures -1 mV, and LL measures zero. Estimate the direction and magnitude of the cardiac vector in the frontal plane. You may assume the distance between shoulders of the subject is roughly 50 cm.

2. [35 pts] An instrumentation amplifier (IA) and driven right leg (DRL) amplifier are connected as shown below to record a single-lead electrocardiogram while actively grounding the body. The electrode-skin interface resistances are $R_{RA} = 95 \text{ k}\Omega$, $R_{LA} = 105 \text{ k}\Omega$, and $R_{RL} = 100 \text{ k}\Omega$. All opamps are ideal with infinite input impedance. The IA resistances are $R_1 = 490 \text{ k}\Omega$, $R_2 = 20 \text{ k}\Omega$, $R_3 = 10 \text{ k}\Omega$ and $R_4 = 200 \text{ k}\Omega$, all with 0.5 % tolerance. The DRL resistances are $R_a = 10 \text{ k}\Omega$, $R_f = 1 \text{ M}\Omega$, and $R_o = 5 \text{ M}\Omega$.

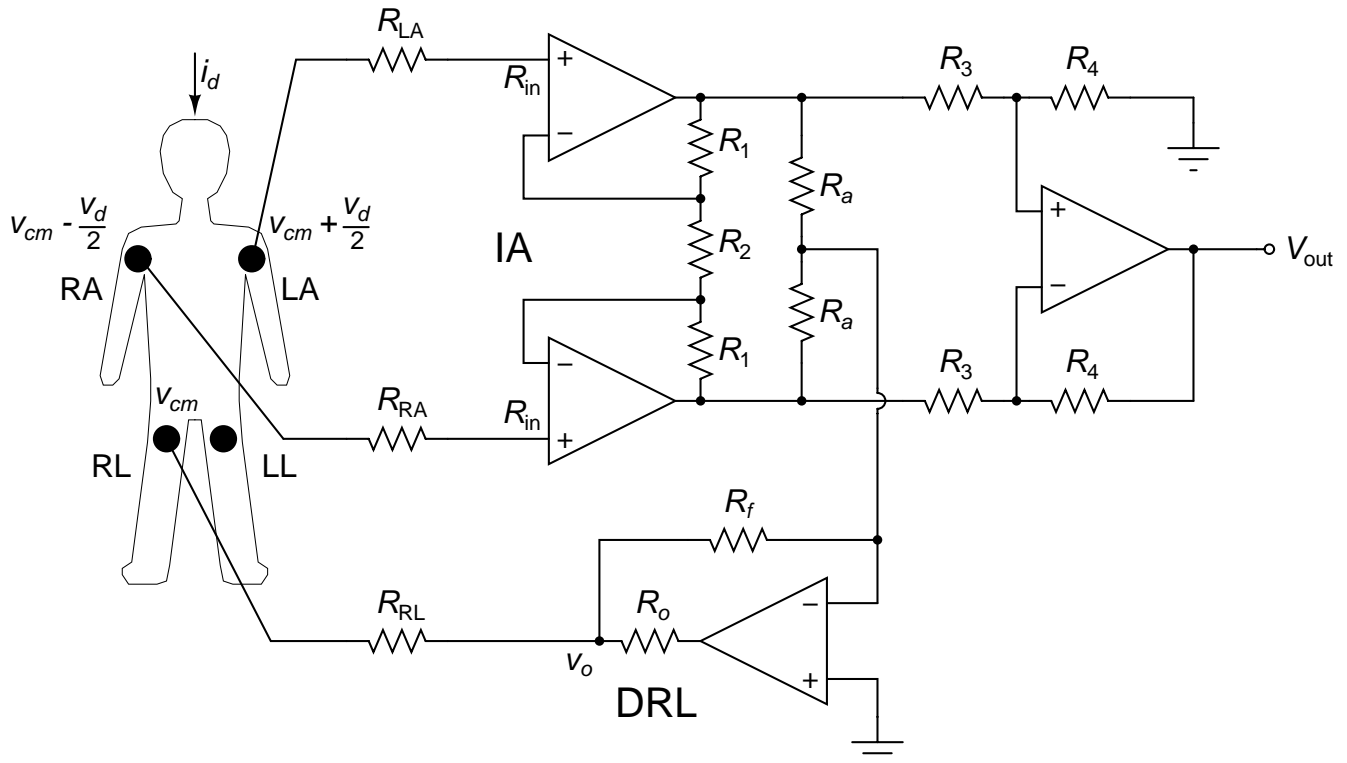

- (a) [5 pts] What ECG lead does the IA output V_{out} represent, and with what voltage gain?

(b) [5 pts] Find the common-mode rejection ratio (CMRR) of the IA.

(c) [5 pts] Considering 1 pF capacitance to ground on the input lines to the IA, at what frequency does the CMRR start to degrade?

- (d) [10 pts] For a displacement current i_d with $5 \mu\text{A}$ peak-to-peak amplitude entering the body, find the peak-to-peak amplitude of the common-mode voltage v_{cm} in the body, with the DRL connection as shown. How much improvement does the DRL active grounding offer over a passive ground connection, where the RL electrode is directly connected to ground without the DRL amplifier?

(e) [5 pts] The peak-to-peak amplitude of the differential signal v_d on the ECG lead is 1 mV. Find the corresponding signal-to-noise ratio (SNR) at the output of the instrumentation amplifier.

(f) [5 pts] What purpose does the resistance R_o in the DRL feedback loop serve? How does it affect the output impedance on the v_o node?

3. [20 pts] Consider a PO_2 sensor consisting of a Clark electrode and a transimpedance amplifier (TIA). The blood sample enters and exits the chamber of the sensor at a constant flow rate $\phi = 10 \text{ mL/s}$. The values of TIA resistances are $R_1 = R_2 = 10 \text{ M}\Omega$ and $R_3 = 1 \text{ k}\Omega$. The following equations may be useful:

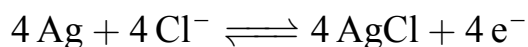
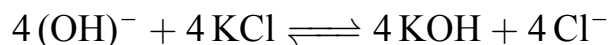

$$I = 4 F [\text{O}_2] \phi$$

where $F = 96,485 \text{ C/mol}$ is the Faraday constant.

- (a) [10 pts] Complete the diagram of the sensor below. Indicate and specify any electrodes, membranes, and buffer solutions, as well as any additional electrical components. You have two 1.2V batteries available, but no other voltage sources.

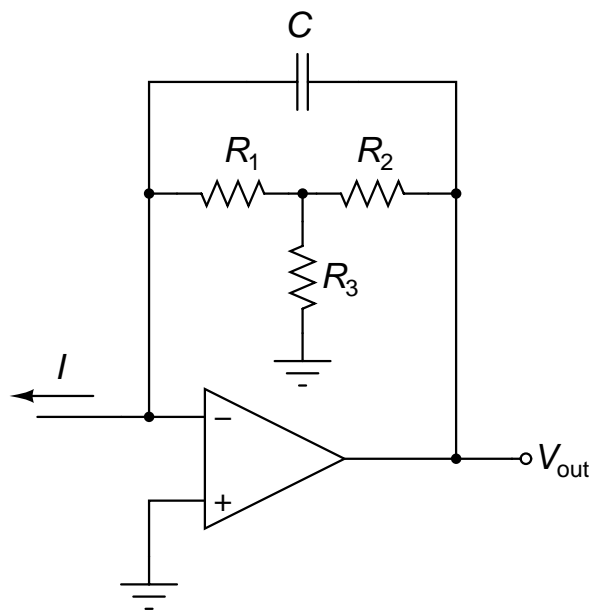

(b) [5 pts] Find the sensitivity of the voltage output V_{out} to oxygen concentration $[O_2]$ in the sample at steady-state.

(c) [5 pts] Find an appropriate value of the capacitance C in order to acquire the output voltage $V_{out}(t)$ at 10 samples per second.

4. [25 pts] Circle the **best answer (only one answer per question)**:

(a) [4 pts] Inertance of fluid in a catheter tube depends on:

- i. Viscosity of the fluid
- ii. Mass density of the fluid
- iii. Elasticity of the fluid
- iv. All of the above
- v. None of the above

(b) [4 pts] Beer's law quantifies:

- i. Alcohol content
- ii. Blood velocity
- iii. Tissue conductivity
- iv. All of the above
- v. None of the above

(c) [4 pts] PCO_2 is measured using:

- i. A Severinghaus electrode
- ii. A pulse oximeter
- iii. A tonometer
- iv. All of the above
- v. None of the above

(d) [4 pts] Functional near-infrared spectroscopy (fNIRS) measures:

- i. Activity in the brain
- ii. Oxygenation in the blood
- iii. Back-scattered light intensity
- iv. All of the above
- v. None of the above

(e) [9 pts] Indicate for each statement below whether it is true or false:

- i. **TRUE / FALSE:** The cardiac vector magnitude depends on the distance between the heart and the electrodes.
- ii. **TRUE / FALSE:** The Wilson Central Terminal is located in the right leg.
- iii. **TRUE / FALSE:** Common-mode interference from line noise limits the precision of biopotential measurement.
- iv. **TRUE / FALSE:** The tipped manometer reliably measures the waveform of local blood pressure.
- v. **TRUE / FALSE:** Rapid bolus injection is an indicator-dilution method for measuring cardiac output.
- vi. **TRUE / FALSE:** The Doppler flowmeter transduces blood velocity into sound pressure.
- vii. **TRUE / FALSE:** A buffered solution of KCl serves as a stable reference in a pH sensor.
- viii. **TRUE / FALSE:** An ion-sensitive field-effect transistor transduces ionic charge into conductance.
- ix. **TRUE / FALSE:** A pulse oximeter measures the electrocardiogram optically.